

**BOSCH**

Invented for life

# Bosch Mega Power Plus

## 59095 - Maintenance Free / Calcium, Calcium Technology

### Applications

Passenger Vehicles

### Bosch Master Data

Short Order Part Number

**59095**

Product Series

**Mega Power Plus**

Bosch 13 Digit Part Number

**0092S37481HH0**

Technology

**Calcium, Calcium**

EAN Barcode

**4047025475457**

Warranty Period

Refer [www.boschaftermarket.com.au](http://www.boschaftermarket.com.au)

Refer [www.boschaftermarket.co.nz](http://www.boschaftermarket.co.nz)

### Technical Information

Nominal Voltage

**12V**

Nominal Capacity (20HR)

**90 AH**

Reserve Capacity (RC)

**160 Mins**

Cold Cranking Amperes (CCA)

**912 Amps**

#### Case Size Dimension

Length

**315 mm (12.4 inches)**

Width

**175 mm (6.89 inches)**

Container Height

**166 mm (6.53 inches)**

Total Height (with Terminal)

**190 mm (7.48 inches)**

Approx Weight (Gross)

**21.66 kg (47.65 lbs)**

Terminal / Layout

**(-+)**

Container Material

**Polypropylene**

Lid Design

**Labrynth Lid**

Base Hold Down

**B3**

# Product Dimension & Design

## Terminal

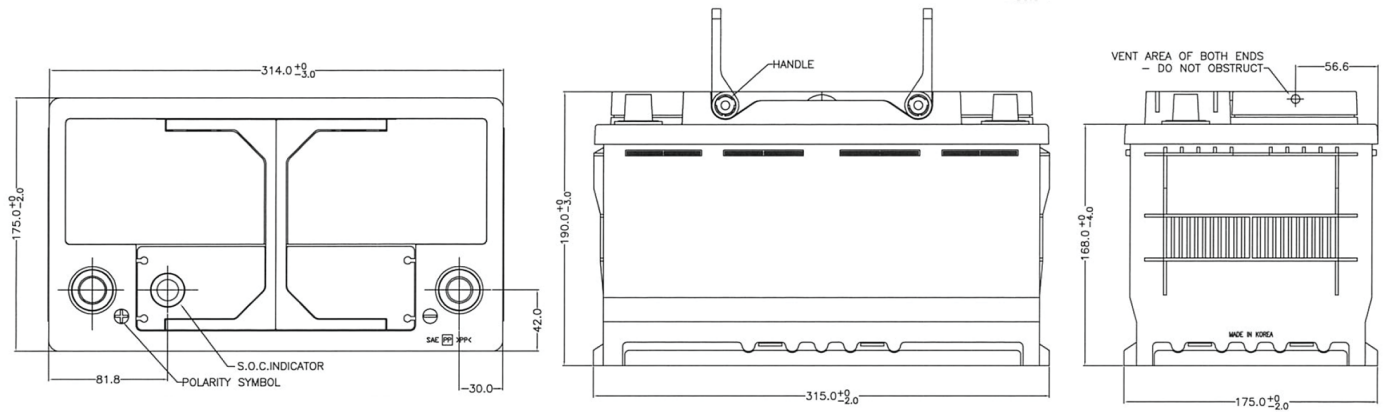
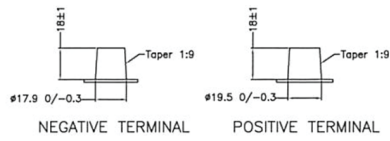

# Product Performance Overview

## Depth of Discharge Cycling Test

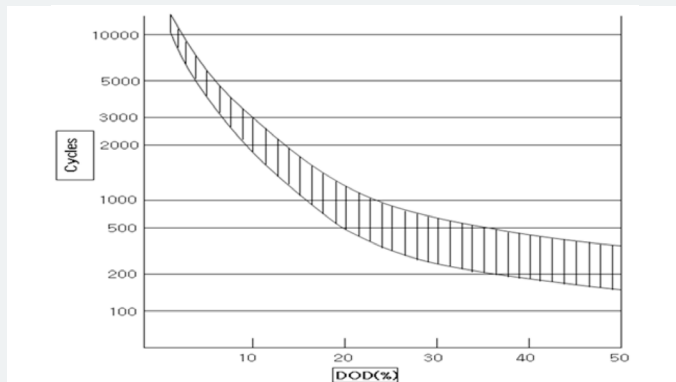

## Discharge Characteristics Test

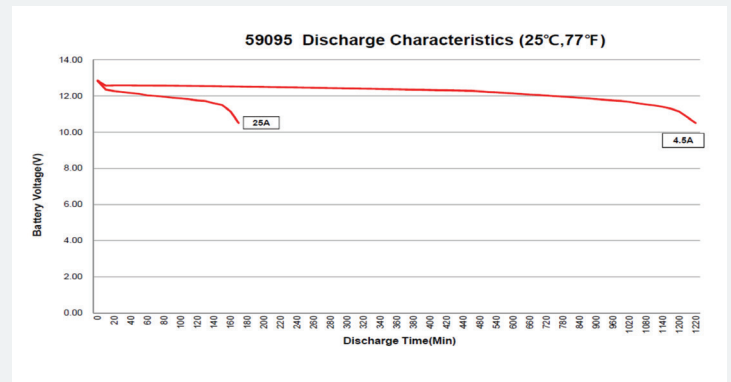

Your address for genuine Bosch quality:

**Dealer stamp here:**