

**BOSCH**

Invented for life

# Bosch SMT Series

## 31-1000 – Mega Power / Calcium, Calcium Technology

### Applications

Heavy Commercial Vehicles

### Bosch Master Data

Short Order Part Number	Bosch 13 Digit Part Number	EAN Barcode
31-1000	0092S37462HHO	4047025524339
Product Series	Technology	Warranty Period
SMT Mega Power	Calcium, Calcium Maintenance Free (MF)	Refer <a href="http://www.boschaftermarket.com.au">www.boschaftermarket.com.au</a> Refer <a href="http://www.boschaftermarket.co.nz">www.boschaftermarket.co.nz</a>

### Technical Information

Nominal Voltage	Nominal Capacity (20HR)	Reserve Capacity
12V	100 AH	160 Mins
Cold Cranking Amperes (CCA)		
1000 Amps		

#### Case Size Dimension

Length	Width	Container Height
330mm (13 inches)	173mm (6.81 inches)	217mm (8.54 inches)
Total Height (with Terminal)		
240mm (9.40 inches)		

Approx Weight (Gross)	Terminal	Grid
26.30 kg (57.9 lbs)	G (Standard)	Expanded
Container Material	Lid Design	
Polypropylene	Labrynth Lid	
Rated Capacity		Internal Battery Resistance
Mins @ 25A = 160 (20hr, 1.75V/cell, 26.7°C/80°F) = 100 AH		2.9mΩ
Operating Temp. Range	Nominal Operating Temp. Range	Self Discharge
Discharge: -30~60°C (-22~140°F)	25°C/77°F	Refer chart

# Product Dimension & Design

■ G (Standard)

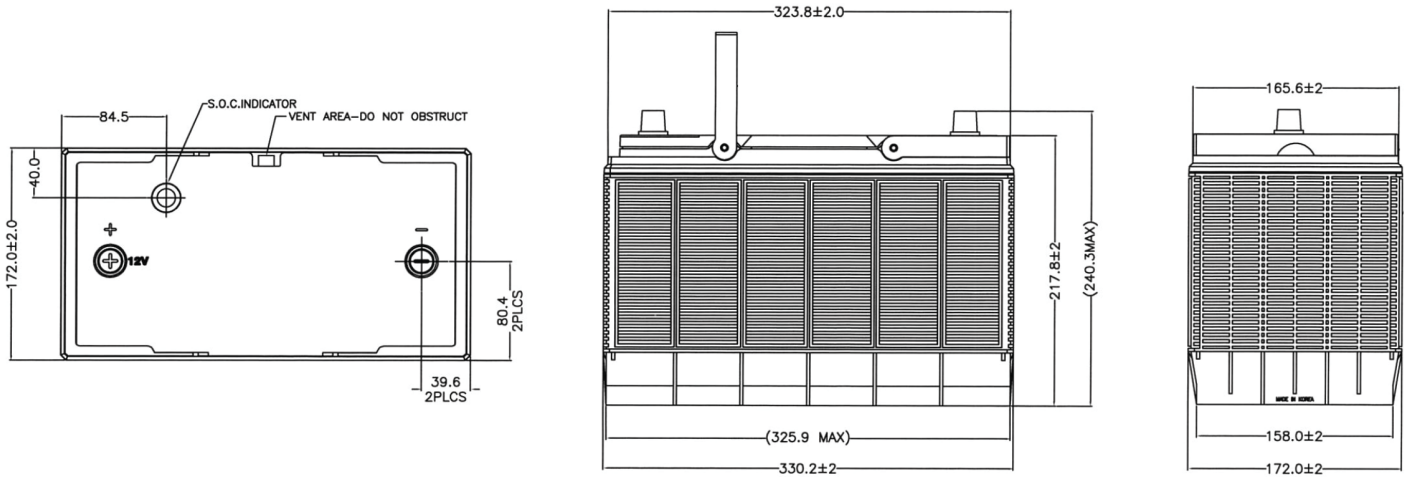
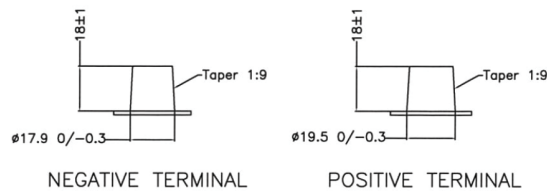

# Product Performance Overview

## Depth of Discharge Cycling Test

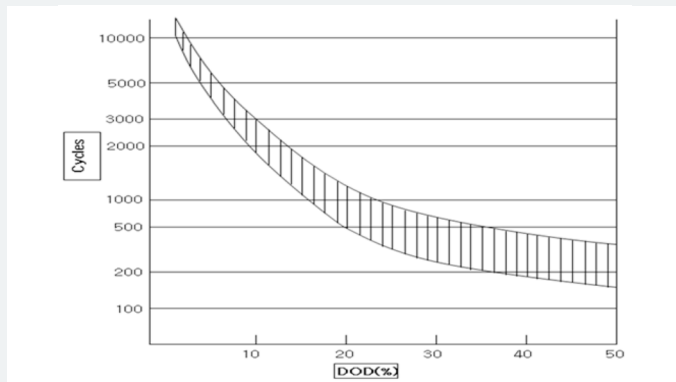

## Discharge Characteristics Test

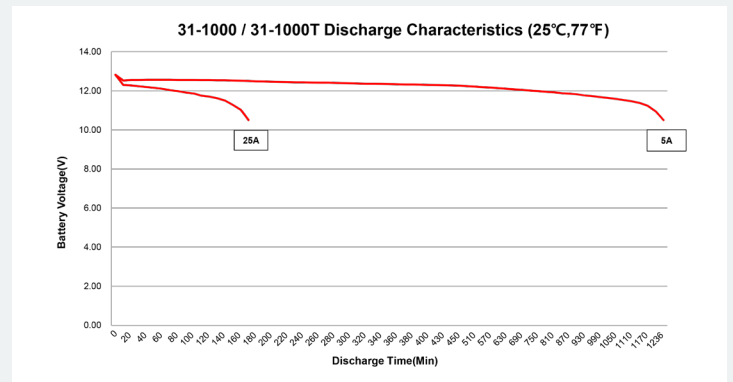

Your address for genuine Bosch quality:

**Dealer stamp here:**