

**BOSCH**

Invented for life

Bosch SMT Series

31-1000T – Mega Power / Calcium, Calcium Technology

Applications

Heavy Commercial Vehicles

Bosch Master Data

Short Order Part Number	Bosch 13 Digit Part Number	EAN Barcode
31-1000T	0092S37463HH0	4047025524346
Product Series	Technology	Warranty Period
SMT Mega Power	Calcium, Calcium Maintenance Free (MF)	Refer www.boschaftermarket.com.au Refer www.boschaftermarket.co.nz

Technical Information

Nominal Voltage	Nominal Capacity (20HR)	Cold Cranking Amperes (CCA)
12V	100 Mins	1000 Amps

Case Size Dimension

Length	Width	Container Height
330mm (13 inches)	173mm (6.81 inches)	217mm (8.54 inches)
Total Height (with Terminal)		
240mm (9.40 inches)		

Approx Weight (Gross)	Terminal	Grid
26.30 kg (57.9 lbs)	G (Threaded)	Expanded
Container Material	Lid Design	
Polypropylene	Labrynth Lid	
Rated Capacity		Internal Battery Resistance
Mins @ 25A = 160 (20hr, 1.75V/cell, 26.7°C/80°F) = 100 AH		2.9mΩ
Operating Temp. Range	Nominal Operating Temp. Range	Self Discharge
Discharge: -30~60°C (-22~140°F)	25°C/77°F	Refer chart

Product Dimension & Design

G (Threaded)

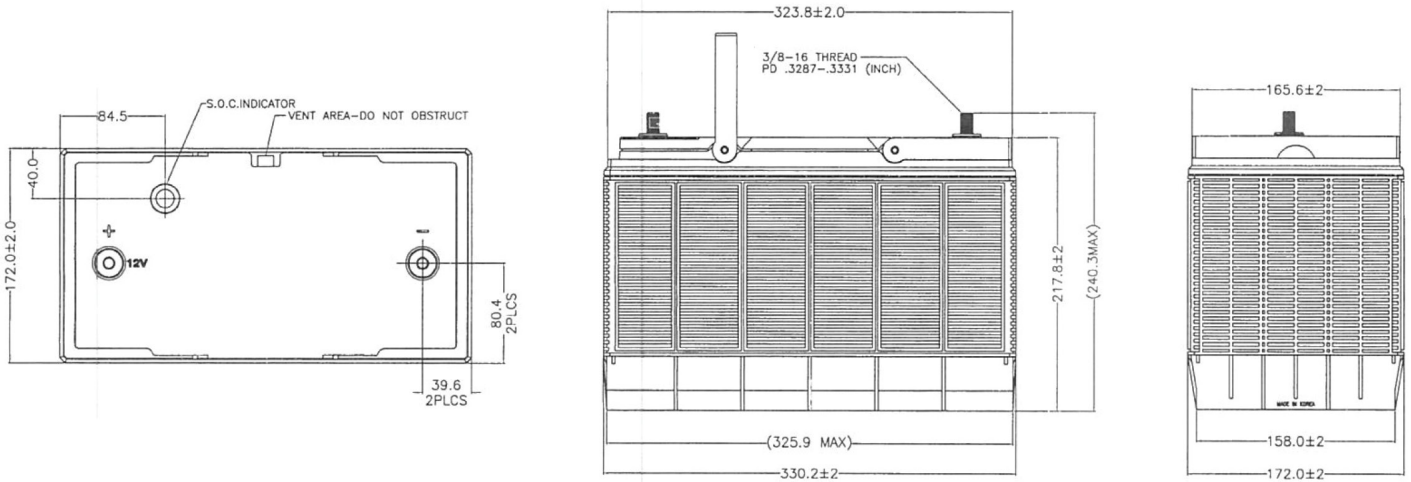

Product Performance Overview

Depth of Discharge Cycling Test

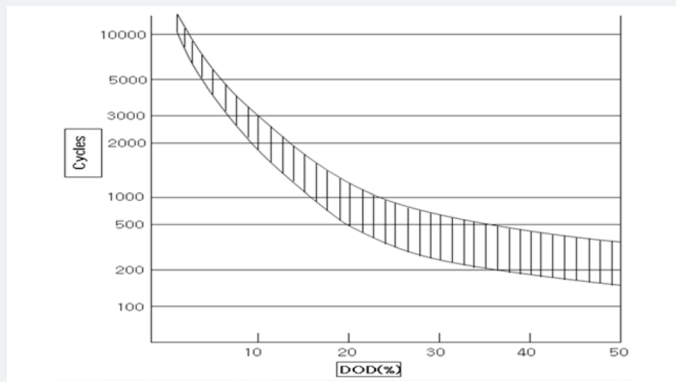

Discharge Characteristics Test

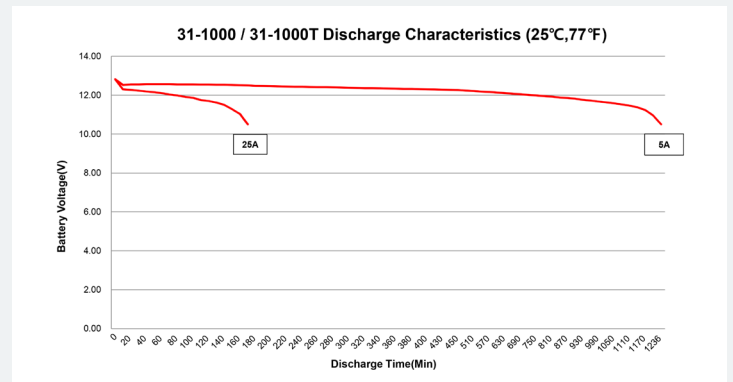

Your address for genuine Bosch quality:

Dealer stamp here: