



BOSCH

Invented for life

Bosch SM Mega Power Plus

55066 - Maintenance Free / Calcium, Calcium Technology

Applications

Passenger Vehicle



Image is generic & may vary to actual product

Bosch Master Data

Short Order Part Number

55066

Bosch 10 Digit Part Number

0092S37019

EAN Barcode

4047026240139

Product Series

SM Mega Power Plus

Technology

Calcium, Calcium

Warranty Period

Refer www.boschaftermarket.com.au

Refer www.boschaftermarket.co.nz

Technical Information

Nominal Voltage

12V

Nominal Capacity (20HR)

50AH

Reserve Capacity

84 Mins

Cold Cranking Amperes (CCA)

430 Amps

Case Size Dimension

Length

208 mm (8.19 inches)

Width

175 mm (6.89 inches)

Container Height

165.5 mm (6.51 inches)

Total Height (with Terminal)

190 mm (7.48 inches)

Case Size

H4/L1

Approx Weight (Gross)

12.40 kg (27.30 lbs)

Terminal

(-+)

Container Material

Polypropylene

Lid Design

Labrynth Lid

Base Hold Down

B3

Product Dimension & Design

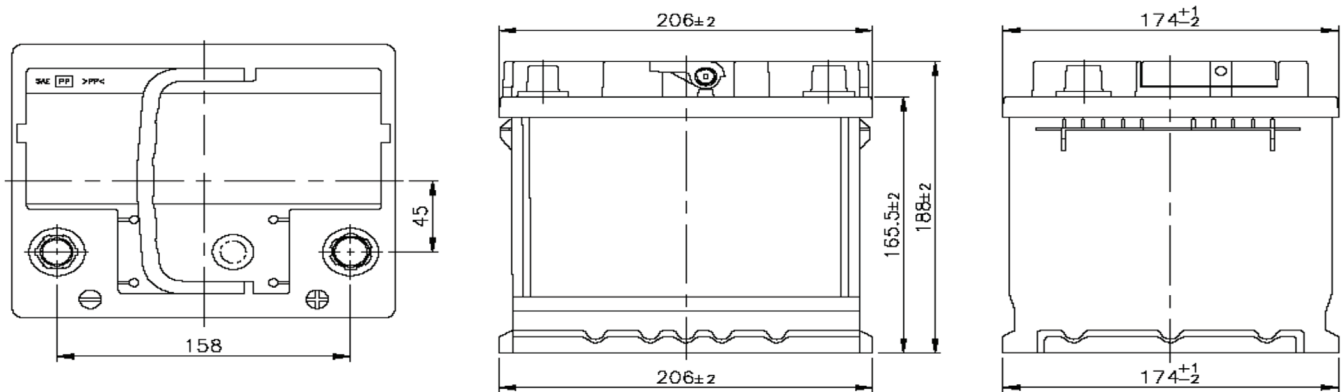

Product Performance Overview

Depth of Discharge Cycling Test

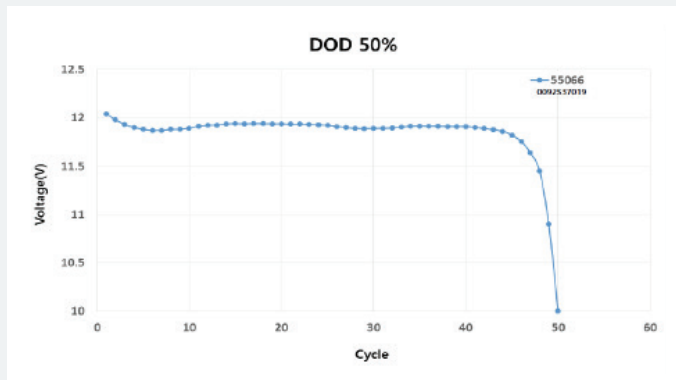

Discharge Characteristics Test

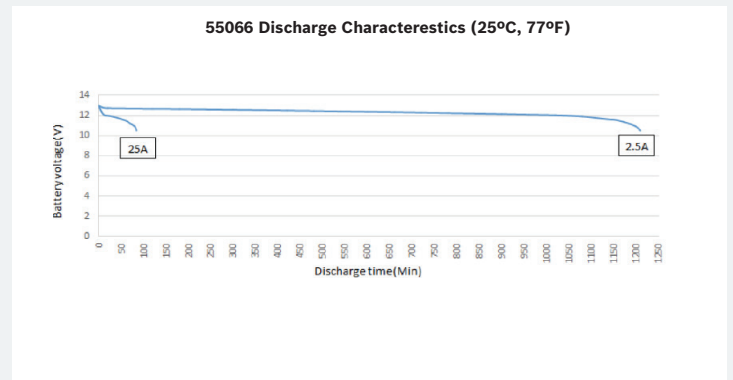

Your address for genuine Bosch quality:

Dealer stamp here: