



BOSCH

Invented for life

Bosch SM Mega Power Silver

575.068 - Maintenance Free / Calcium, Silver Technology

Applications

Passenger Vehicle
Light Commercial Vehicle



Image is generic & may vary to actual product

Bosch Master Data

Short Order Part Number

575.068

Product Series

SM Mega Power Silver

Bosch 10 Digit Part Number

0092S57049

Technology

Calcium, Silver

EAN Barcode

4047025475983

Warranty Period

Refer www.boschaftermarket.com.au

Refer www.boschaftermarket.co.nz

Technical Information

Nominal Voltage

12V

Nominal Capacity (20HR)

75AH

Reserve Capacity

120 Mins

Cold Cranking Amperes (CCA)

680 Amps

Case Size Dimension

Length

278 mm (10.94 inches)

Width

175 mm (6.89 inches)

Container Height

153 mm (6.02 inches)

Total Height (with Terminal)

175 mm (6.89 inches)

Case Size

LB2

Approx Weight (Gross)

17.35 kg (38.17 lbs)

Terminal

(-+)

Container Material

Polypropylene

Lid Design

Labrynth Lid

Base Hold Down

B3

Product Dimension & Design

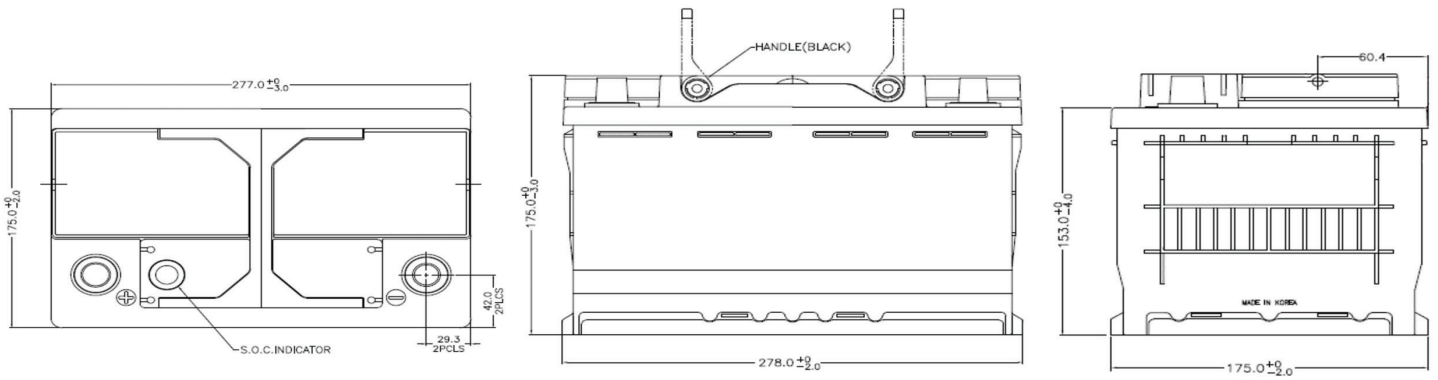

Product Performance Overview

Depth of Discharge Cycling Test

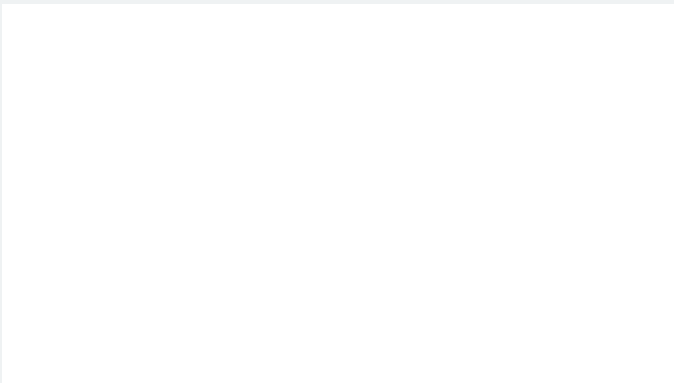

Discharge Characteristics Test

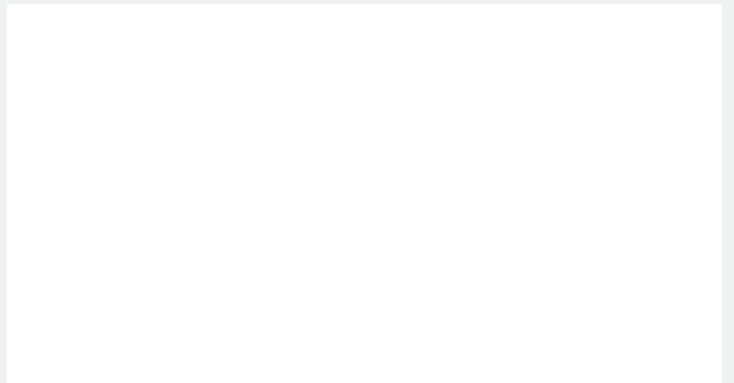

Your address for genuine Bosch quality:

Dealer stamp here: