

**BOSCH**

Invented for life

Bosch SMT Mega Power Plus (T4)

105D31L – 12V Calcium, Calcium Technology

Applications

Light & Heavy Commercial Applications including Industrial



Bosch Master Data

Short Order Part Number	Bosch 13 Digit Part Number	EAN Barcode
105D31L	0092T47020HH0	4047025475600
Product Series	Technology	Warranty Period
SMT Mega Power Plus (T4)	Calcium, Calcium	Refer www.boschaftermarket.com.au
		Refer www.boschaftermarket.co.nz

Technical Information

Nominal Voltage	Nominal Capacity (20HR)	Reserve Capacity
12V	95 AH	170 Mins

Cold Cranking Amperes (CCA)

770 Amps

Case Size Dimension

Length	Width	Container Height
305 mm (12.00 inches)	172 mm (6.77 inches)	200 mm (7.87 inches)

Total Height (with Terminal)

222 mm (8.74 inches)

Approx Weight (Gross)	Terminal	Container Material
21.75 kg (47.85 lbs)	(-+)	Polypropylene

Lid Design

Base Hold Down

Labrynth Lid

B7

Product Dimension & Design

A (Standard)

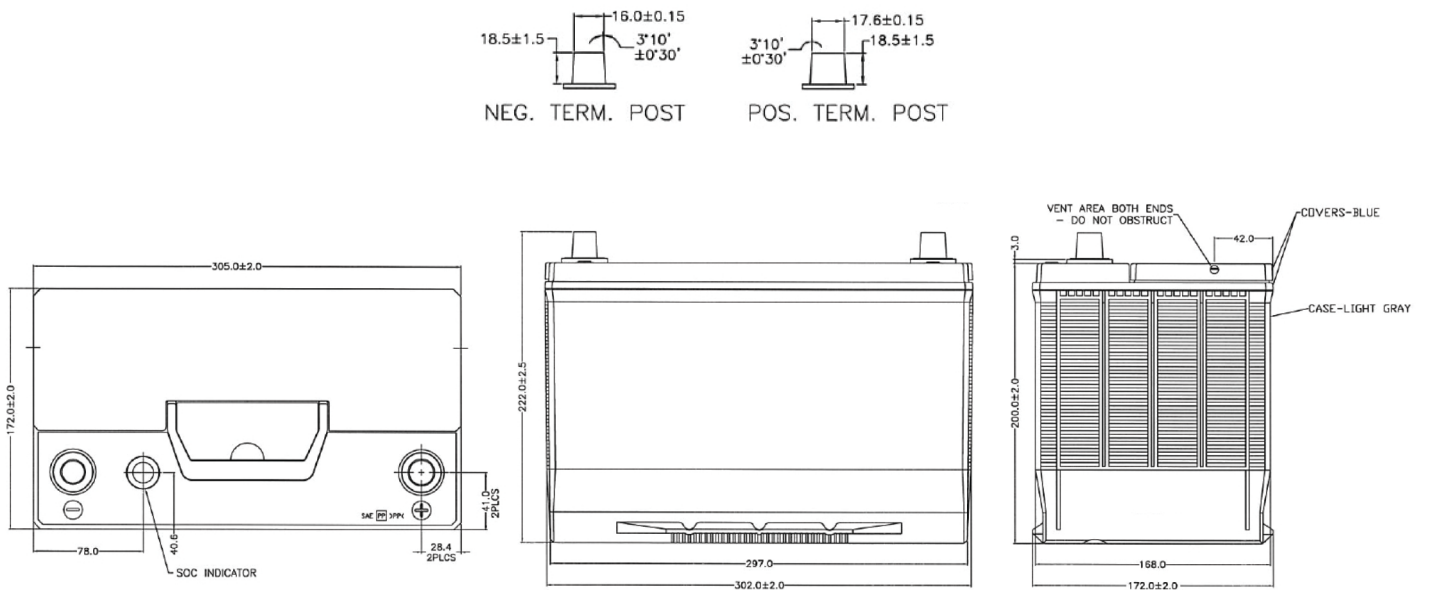

Product Performance Overview

Depth of Discharge Cycling Test

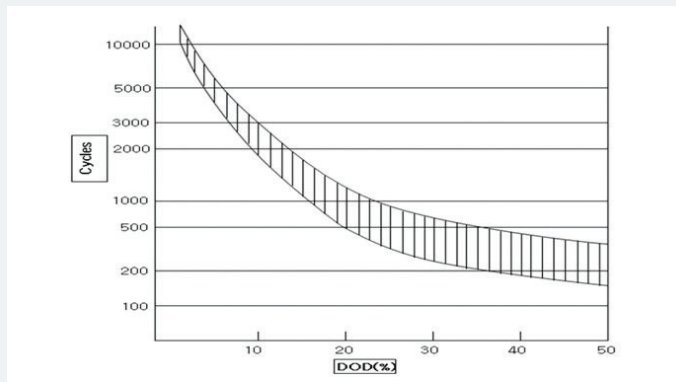

Discharge Characteristics Test

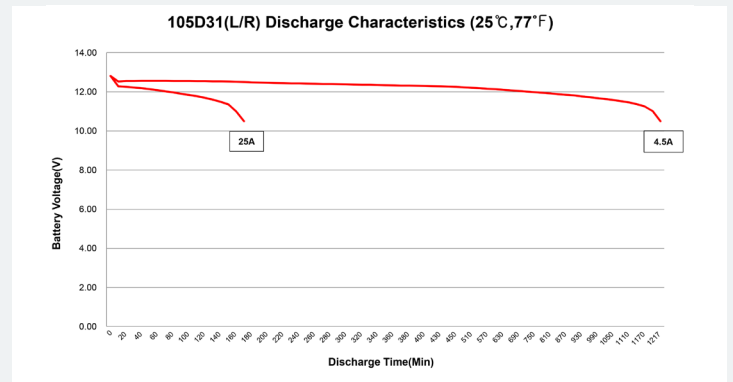

Your address for genuine Bosch quality:

Dealer stamp here: