

**BOSCH**

Invented for life

# Bosch ST Hightec

## LB3-EFB – Maintenance Free Technology

### Applications

Passenger Vehicles

### Bosch Master Data

Short Order Part Number	Bosch 10 Digit Part Number	EAN Barcode
LB3-EFB	0092S67125	4047026478143
Product Series	Technology	Warranty Period
ST Hightec EFB	EFB (Enhanced Flooded Battery)	Refer <a href="http://www.boschaftermarket.com.au">www.boschaftermarket.com.au</a>
		Refer <a href="http://www.boschaftermarket.co.nz">www.boschaftermarket.co.nz</a>

### Technical Information

Nominal Voltage	Nominal Capacity (20HR)	Reserve Capacity
12V	65 AH	110 mins

Coldcranking Amps (CCA)  
650 Amps

**Case Size Dimension**

Length	Width	Container Height
277 mm (10.90 inches)	175 mm (6.89 inches)	152 mm (5.98 inches)

Total Height (with Terminal)  
175 mm (6.89 inches)

Approx Weight	Terminal	Container Material
17.0 kg (37.4 lbs)	(+)	Polypropylene
Lid Design	Base Hold Down	
Labrynth Lid	B1	

# Product Dimension & Design

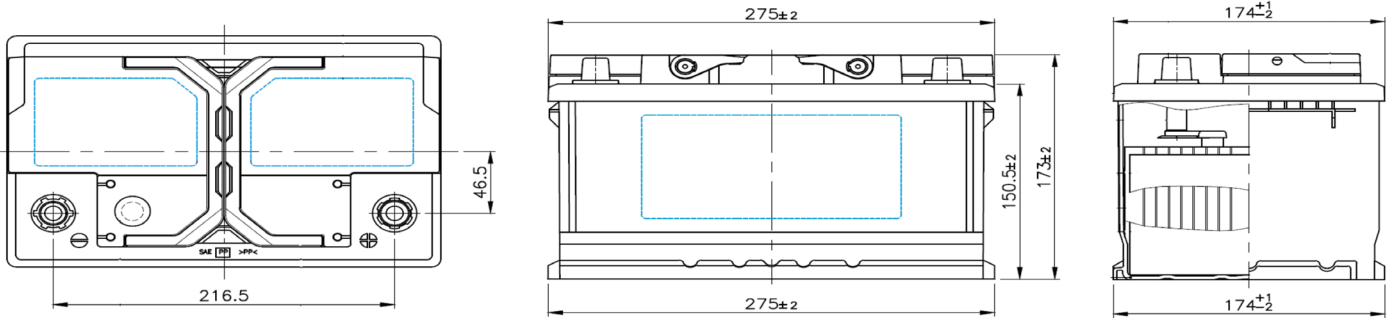

# Product Performance Overview

## Depth of Discharge Cycling Test

## Discharge Characteristics Test

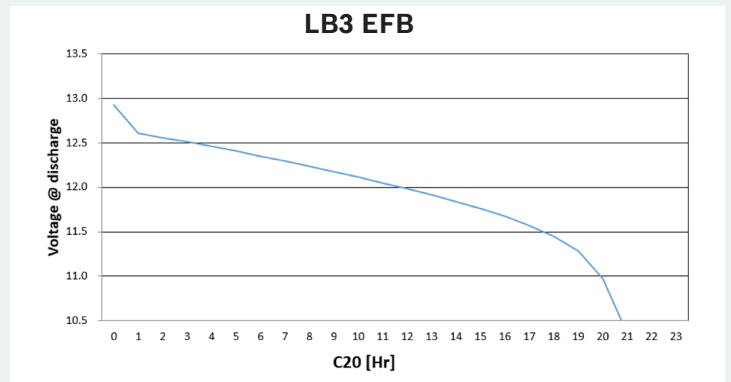
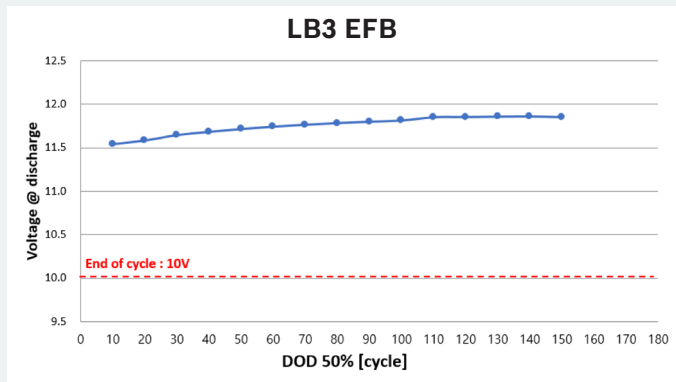

Your address for genuine Bosch quality:

**Dealer stamp here:**