

**BOSCH**

Invented for life

# Bosch SMT Mega Power Plus

## N100 (130E41R) – 12V Calcium-Calcium Technology

### Applications

Light & Heavy Commercial Applications including 4WD

### Bosch Master Data

Short Order Part Number	Bosch 13 Digit Part Number	EAN Barcode
N100 (130E41R)	0092S47061HH0	4047025571241
Product Series	Technology	Warranty Period
SMT Mega Power Plus (T4)	Calcium, Calcium	Refer <a href="http://www.boschaftermarket.com.au">www.boschaftermarket.com.au</a>
		Refer <a href="http://www.boschaftermarket.co.nz">www.boschaftermarket.co.nz</a>

### Technical Information

Nominal Voltage	Nominal Capacity (20HR)	Reserve Capacity
12V	110 AH	190 Mins
Cold Cranking Amperes (CCA)		
700 Amps		
<b>Case Size Dimension</b>	<hr/>	
Length	Width	Container Height
406mm (16 inches)	172mm (6.81 inches)	211mm (8.30 inches)
Total Height (with Terminal)		
231mm (9 inches)		
<hr/>		
Approx Weight	Terminal	Grid Design
27.45 kg (60.4 lbs)	B (Standard)	Expanded
Container Material	Lid Design	
Polypropylene	Labrynth Lid	
Rated Capacity		Internal Battery Resistance
Mins @ 25A = 190 (20hr, 1.75V/cell, 26.7°C/80°F) = 110 AH		3.8mΩ
Operating Temp. Range	Nominal Operating Temp. Range	Self Discharge
Discharge: -30~60°C (-22~140°F)	25°C/77°F	Refer chart

# Product Dimension & Design

## ■ B (Standard)

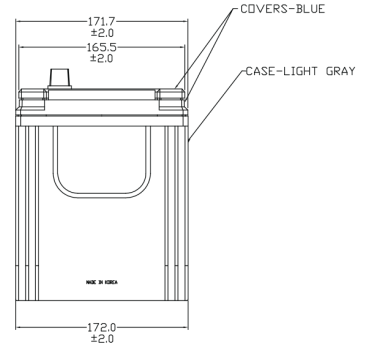
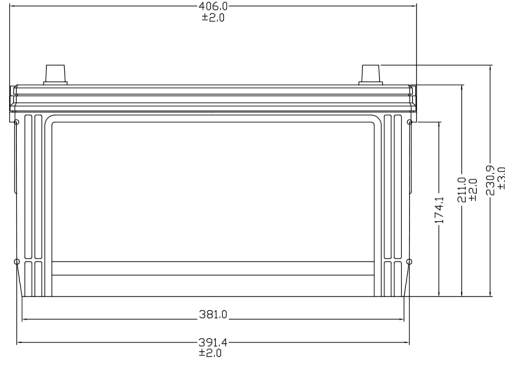
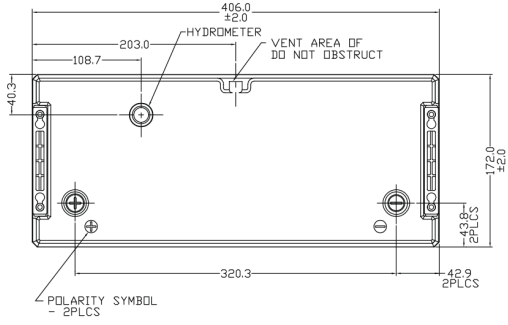
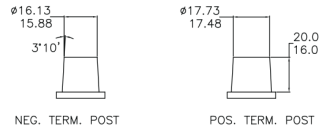

Your address for genuine Bosch quality:

**Dealer stamp here:**