

Overview

The rechargeable batteries are lead-lead dioxide systems. The dilute sulfuric acid electrolyte is absorbed by separators and plates and thus immobilized. Should the battery be accidentally overcharged producing hydrogen and oxygen, special oneway valves allow the gases to escape thus avoiding excessive pressure build-up. Otherwise, the battery is completely sealed and is, therefore, maintenance-free, leak proof and usable in any position.

Battery Construction

Component	Positive plate	Negative plate	Container	Cover	Safety valve	Terminal	Separator	Electrolyte
Raw material	Lead dioxide	Lead	ABS	ABS	Rubber	Copper	Fiberglass	Sulfuric acid

General Features

- Absorbent Glass Mat (AGM) technology for efficient gas recombination of up to 99% and freedom from electrolyte maintenance or water adding.
- Not restricted for air transport-complies with IATA/ICAO Special Provision A67.
- UL-recognized component.
- Computer designed lead, calcium tin alloy grid for high power density.
- Long service life, float or cyclic applications.
- Maintenance-free operation.
- Low self discharge.
- Case and cover available in both standard and flame retardant ABS.

Battery Specification

Performance Characteristics	
Nominal Voltage	2V
Number of cell	1
Design Life	20 years
Nominal Capacity 77°F(25°C)	
10 hour rate (100.0A, 1.8V)	1000Ah
5 hour rate (175A, 1.75V)	875Ah
1 hour rate (555A, 1.75V)	555Ah
Internal Resistance	
Fully Charged battery 77°F(25°C)	≤0.3 mOhms
Self-Discharge	
3% of capacity declined per month at 20°C (average)	
Operating Temperature Range	
Discharge	-20~60°C
Charge	-10~60°C
Storage	-20~60°C
Max. Discharge Current 77°F(25°C)	4000A(5s)
Charge Methods: Constant Voltage Charge 77°F(25°C)	
Cycle use	2.40-2.45VPC
Maximum charging current	250A
Temperature compensation	-5.0mV/°C
Standby use	2.20-2.30VPC
Temperature compensation	-3.3mV/°C

Dimensions and Weight

Length(mm / inch)	229/9.02
Width(mm / inch)	186/7.32
Height(mm / inch)	555/21.85
Total Height(mm / inch)	566/22.28
Approx. Weight(Kg / lbs)	57/125.7

* Weight deviation: ± 3%

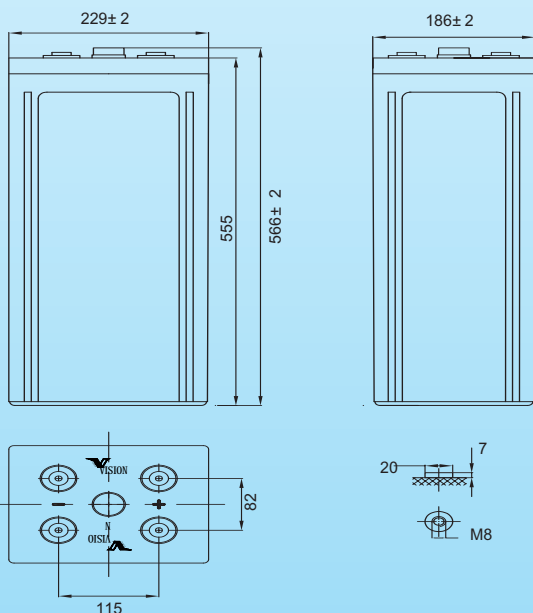

Discharge Constant Current (Amperes at 77°F25°C)

End Point Volts/Cell	15min	30min	45min	1h	2h	3h	5h	10h
1.60	1325	990	725	570	350	270	190	111
1.65	1260	940	700	565	345	265	185	108
1.70	1180	880	670	560	340	260	180	105
1.75	1030	830	650	555	335	255	175	102
1.80	920	730	612	550	330	252	172	100

Discharge Constant Power (Watts at 77°F25°C)

End Point Volts/Cell	15min	30min	45min	1h	2h	3h	5h	10h
1.60	2210	1750	1325	1105	740	580	410	260
1.65	2120	1680	1290	1090	725	570	400	250
1.70	2000	1600	1250	1070	705	560	390	240
1.75	1830	1500	1200	1050	695	540	380	230
1.80	1650	1380	1160	1025	680	530	370	205

(Note)The above characteristics data are average values obtained within three charge/discharge cycles not the minimum values.All data shall be changed without notice,Vision reserves the right to explain and update the information contained hereinto.

