

### Overview

The rechargeable batteries are lead-lead dioxide systems. The dilute sulfuric acid electrolyte is absorbed by separators and plates and thus immobilized. Should the battery be accidentally overcharged producing hydrogen and oxygen, special oneway valves allow the gases to escape thus avoiding excessive pressure build-up. Otherwise, the battery is completely sealed and is, therefore, maintenance-free, leak proof and usable in any position.



### General Features

- Positive and negative plates in lead-calcium tin alloy;
- Superior energy density;
- Operates at a low internal pressure;
- Gas Recombination;
- Usable in any orientation;
- A recognized component of UL;
- Very high power output;
- Application specific designs;
- A couple Range from 13W to 890W per cell for 10'@1.60Vpc;
- Six months shelf life at 20°C;
- Design life 10 years.

### Dimensions and Weight

Length(mm / inch)	522 / 20.6
Width(mm / inch)	238 / 9.37
Height(mm / inch)	218 / 8.58
Total Height(mm / inch)	223 / 8.78
Approx. Weight(Kg / lbs)	67.5 / 149.0

\* Weight deviation: ± 5%

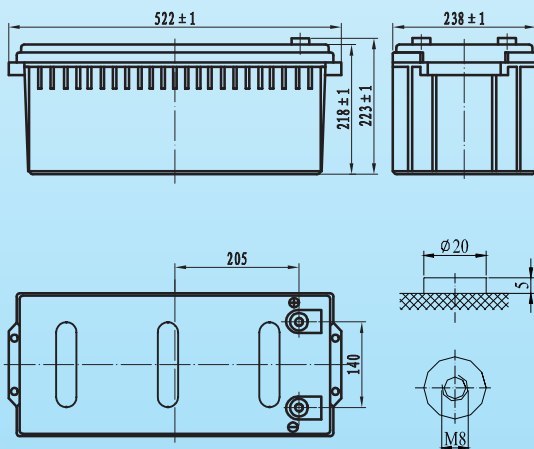

### Battery Specification

Performance Characteristics	
Nominal Voltage	12V
Number of cell	6
Design Life	10 years
Nominal Capacity 68°F(20°C)	
10 min wattage @1.6V	890W/cell
20hour rate (10.8A, 10.5V)	216Ah
10hour rate (20.0A, 10.8V)	200Ah
Internal Resistance	
Fully Charged battery 68°F(20°C)	2.2 mOhms
Self-Discharge	
3% of capacity declined per month at 20°C(average)	
Operating Temperature Range	
Discharge	-20~60°C
Charge	-10~60°C
Storage	-20~60°C
Max. Discharge Current 68°F(20°C)	1300A(5s)
Charge Methods: Constant Voltage Charge 68°F(20°C)	
Cycle use	2.30-2.35VPC
Maximum charging current	55.0A
Temperature compensation	-30mV/°C
Standby use	2.23-2.27VPC
Temperature compensation	-20mV/°C

### Discharge Constant Current (Amperes at 68°F20°C)

End Point						
Volts/Cell	10min	15min	20min	30min	45min	60min
1.60V	523	431	357	283	207	161
1.65V	494	408	338	268	197	154
1.70V	466	386	320	254	187	146
1.75V	437	364	301	239	176	139
1.80V	421	351	292	233	172	136

### Discharge Constant Power (Watts at 68°F20°C)

End Point						
Volts/Cell	10min	15min	20min	30min	45min	60min
1.60V	890	733	608	483	350	280
1.65V	857	707	587	467	340	272
1.70V	824	681	567	452	329	265
1.75V	790	656	546	436	319	257
1.80V	757	630	525	420	308	249

(Note)The above characteristics data are average values obtained within three charge/discharge cycles not the minimum values.All data shall be changed without notice, Vision reserves the right to explain and update the information contained hereinto.



**VISION GROUP**  
Shenzhen Center Power  
Tech.Co.Ltd.,

# HF12-890WS-X

12V 200Ah

