



VISION GROUP
Shenzhen Center Power
Tech.Co.Ltd.,

HFS12-560W-X

12V 150Ah

Overview

The new VISION HFS series batteries are designed for UPS Standby Power Applications requiring high power output. Computer designed grids and optimized plate paste formula produce high energy density and long lasting uninterrupted power for critical systems.



Battery Construction

Component	Positive plate	Negative plate	Container	Cover	Safety valve	Terminal	Separator	Electrolyte
Raw material	Lead dioxide	Lead	ABS	ABS	Rubber	Copper	Fiberglass	Sulfuric acid

General Features

- Positive and negative plates in lead-calcium-tin alloy;
- Superior energy density;
- Operate at a low internal pressure;
- Gas recombination;
- Special separator technology;
- A recognized component of UL, IEC, TLC. etc;
- Container Material ABS(UL 94-HB);
- Very high power output for 5 to 15 minutes supply
- A covered range from 90W to 850W per cell for 15min @ 1.67Vpc;
- Six months shelf life at 20 °C;
- Design life :12+ years at 20 °C;
- Recommended loading 1h and below;

Battery Specification

Performance Characteristics	
Nominal Voltage	12V
Number of cell	6
Design Life	12 years
Nominal Capacity 77°F(25°C)	
15 min wattage @ 1.67VPC	560W/cell
10 hour rate (15.0A,10.8V)	150Ah
20 hour rate (7.80A,10.8V)	156Ah
Internal Resistance	
Fully Charged battery 77°F(25°C)	≤3.5 mOhms
Self-Discharge	
3% of capacity declined per month at 20°C(average)	
Operating Temperature Range	
Discharge	-20~60°C
Charge	-10~60°C
Storage	-20~60°C
Max. Discharge Current 77°F(25°C)	970A(5s)
Charge Methods: Constant Voltage Charge 77°F(25°C)	
Cycle use	2.40~2.45VPC
Maximum charging current	46.8A
Temperature compensation	-30mV/°C
Standby use	2.23~2.30VPC
Temperature compensation	-20mV/°C

Dimensions and Weight

Length(mm / inch)	482/18.9
Width(mm / inch)	170/6.69
Height(mm / inch)	240/9.40
Total Height(mm / inch)	240/9.40
Approx. Weight(Kg / lbs)	45.0/99.2

* Weight deviation: ± 5%

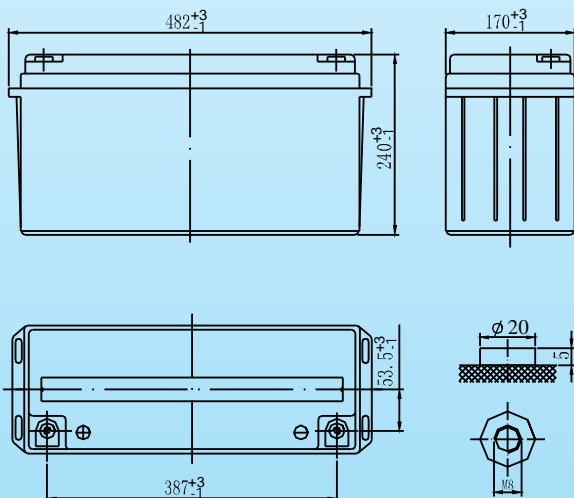

Discharge Constant Current (Amperes at 77°F25°C)

End Voltage Volts/Cell	3min	5min	10min	15min	20min	25min	30min	45min	60min
1.60V	597	501	411	332	284	245	208	139	107
1.65V	586	484	392	318	271	237	205	135	105
1.67V	582	477	387	312	266	234	204	133	104
1.70V	561	454	366	301	258	221	191	130	102
1.75V	543	444	354	291	252	218	186	127	101
1.80V	518	436	342	277	242	208	176	124	98

Discharge Constant Power (Watts at 77°F25°C)

End Point Volts/Cell	3min	5min	10min	15min	20min	25min	30min	45min	60min
1.60V	1147	915	722	600	502	431	370	267	210
1.65V	1130	892	684	571	483	416	362	258	204
1.67V	1123	883	668	560	476	410	359	255	202
1.70V	1103	864	654	550	463	401	347	250	200
1.75V	1076	844	615	527	450	386	333	242	193
1.80V	1047	806	601	502	432	372	320	234	190

(Note)The above characteristics data are average values obtained within three charge/discharge cycles not the minimum values.All data shall be changed without notice,Vision reserves the right to explain and update the information contained hereinto.



VISION GROUP
Shenzhen Center Power
Tech.Co.Ltd.,

HFS12-560W-X

12V 150Ah

