



NPD12950

AGM Deep Cycle Battery

General Features

- Oxygen recombination technology: maintenance-free.
- The patent grid alloy: less gassing, low self-discharging.
- Special paste formula: additives for deep discharge, long cycle life.
- High quality AGM separator: extend cycle life and prevent micro short circuit.
- The patent Nano silica gel electrolytes: improve the deep discharge performance.
- Cast on strap (COS) welding technology for high consistency and reliability.
- ABS container: increase the strength of battery.



Application

- Electric vehicle
- Lawn mowers
- Illumination light
- Wheelchairs
- Sweeper
- Electric toys
- Electric tools
- Golf trolley and golf cart

Specification

Nominal Voltage	12V
Nominal Capacity	95Ah ,C20@1.80Vpc, 25°C(77°F)
Dimension	Length 260mm(10.24 inch)
	Width 168mm(6.61 inch)
	Container Height 215mm(8.46 inch)
	Total Height (With Terminal) 215mm(8.46 inch)
Rated Capacity (25°C/77°F)	95Ah/(20Hr, 1.80V/cell)
	91Ah/(10Hr, 1.80V/cell)
	86Ah/(5Hr, 1.75V/cell)
	77Ah/(3Hr, 1.75V/cell)
Weight	26Kg ±5% (57.32lbs)
	Terminal
Container Material	ABS
Operating Temp. Range	Discharge: -20 to +50°C(-4~122°F)
	Charge: -20 to +50°C(-4~122°F)
Capacity affected by Temperature	Storage: -20 to +50°C(-4~122°F)
	102% @ 40°C(104°F)
	100% @ 25°C(77°F)
	85% @ 0°C(32°F)
	65% @ -15°C(5°F)

Terminal

Unit:mm

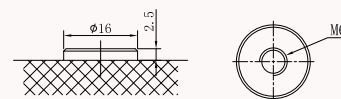

Dimension

Unit:mm

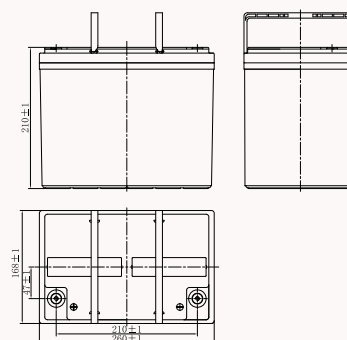

This information is generally descriptive only and is not intended to make or imply any representation, guarantee or warranty with respect to any cells and batteries. Cell and Battery designs/specification are subject to modification without notice. Contact YHI Power for latest information.

YHI POWER Pty. Ltd Melbourne Head Office: 20-22 Venture Way, Braeside, VIC 3195 Ph: 03 9588 1888 Web: yhipower.com.au

Discharge performance

Constant Current Discharge Table (25°C/77°F) Unit: A															
F.V/Time	5min	10min	15min	20min	30min	45min	1h	2h	3h	4h	5h	6h	8h	10h	20h
1.85V/cell	301.6	205.7	175.1	144.0	105.8	75.6	59.9	35.8	24.53	18.69	16.91	12.89	10.08	8.86	4.68
1.80V/cell	325.7	214.4	179.5	147.5	109.3	77.5	61.6	36.6	25.14	19.13	17.14	13.21	10.36	9.14	4.75
1.75V/cell	344.4	224.3	184.3	151.1	112.6	80.7	64.0	37.6	25.81	19.67	17.21	13.68	10.67	9.33	4.82
1.70V/cell	354.3	229.8	190.5	154.9	115.3	82.7	66.1	38.5	26.35	20.25	17.37	14.05	11.05	9.53	4.89
1.65V/cell	360.8	236.9	194.9	158.8	117.9	85.4	68.5	39.4	27.1	20.75	17.37	14.44	11.31	9.70	4.98
1.60V/cell	370.2	246.8	201.8	164.0	121.0	87.7	69.8	40.6	27.9	21.43	17.37	14.81	11.58	9.92	5.06

Constant Power Discharge Table (25°C/77°F) Unit: W															
F.V/Time	5min	10min	15min	20min	30min	45min	1h	2h	3h	4h	5h	6h	8h	10h	20h
1.85V/cell	561.7	386.0	331.2	275.5	204.6	147.3	117.2	70.6	48.6	37.2	33.7	25.72	20.15	17.74	9.40
1.80V/cell	598.5	397.1	335.8	279.1	209.0	149.9	120.0	71.8	49.6	37.9	34.0	26.27	20.66	18.26	9.51
1.75V/cell	617.8	407.9	340.1	283.0	213.5	155.0	123.9	73.4	50.7	38.8	34.0	27.1	21.21	18.60	9.62
1.70V/cell	619.6	410.1	347.7	287.2	217.0	158.1	127.5	75.0	51.6	39.8	34.2	27.8	21.92	18.97	9.76
1.65V/cell	622.0	418.4	352.0	292.9	220.3	162.5	131.6	76.4	52.8	40.6	34.1	28.5	22.39	19.26	9.92
1.60V/cell	623.5	424.8	358.5	298.4	224.3	165.4	133.1	78.0	54.1	41.7	34.0	29.1	22.87	19.66	10.06

Performance Curve

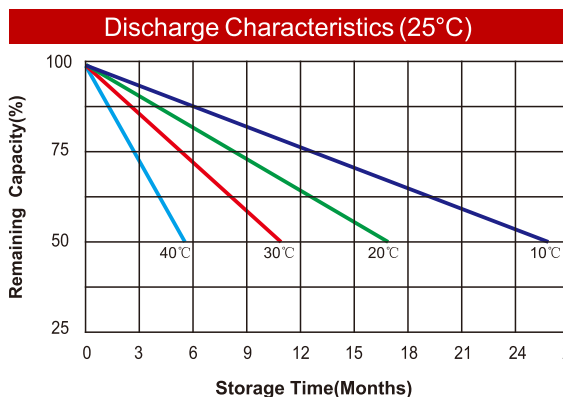
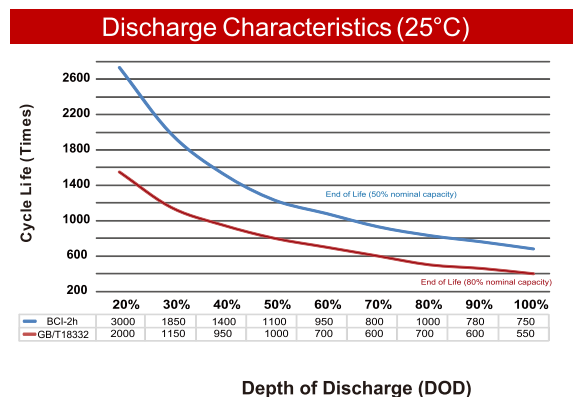
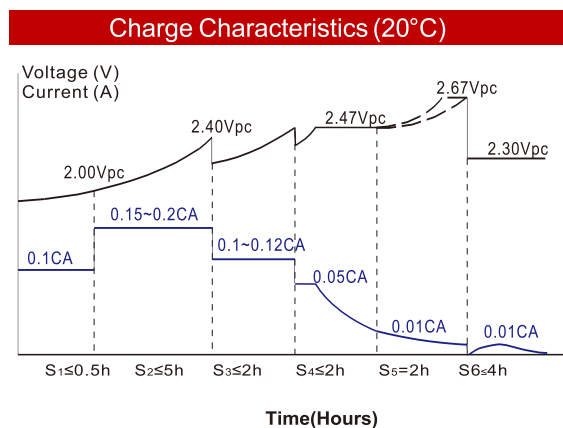
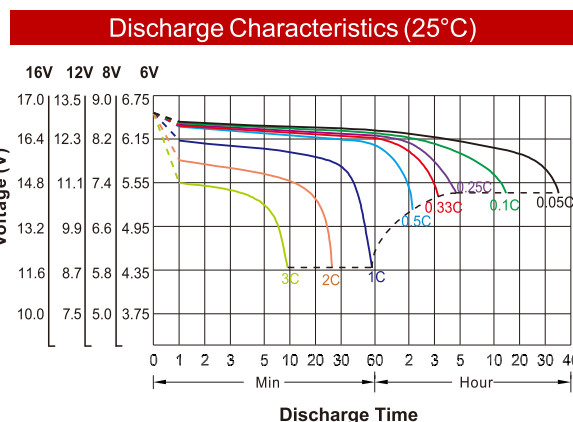

This information is generally descriptive only and is not intended to make or imply any representation, guarantee or warranty with respect to any cells and batteries. Cell and Battery designs/specification are subject to modification without notice. Contact YHI Power for latest information.