



**YHI POWER**  
Battery Power You Can Rely On



# 12.8V Li-ion Battery User's Guide

End User Documentation

Rev 1.0

Nov -01-2024

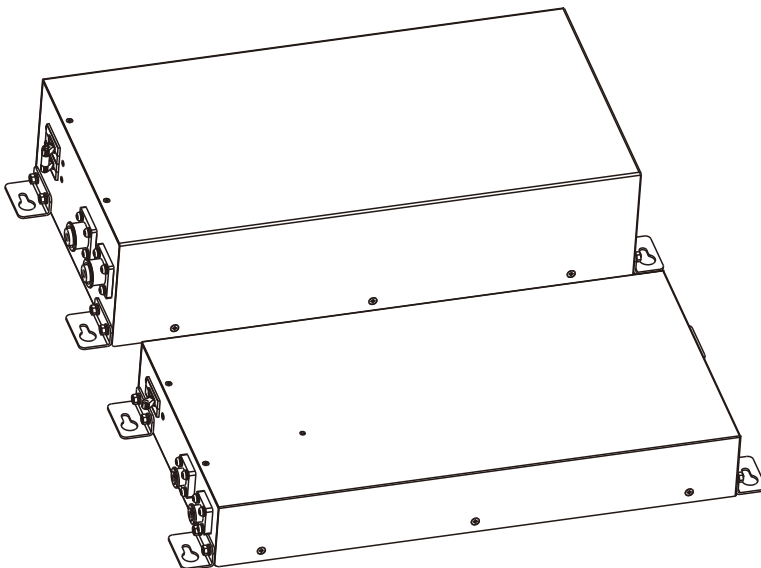

## 12.8V Li-ion Battery

12.8V Li-ion battery is intended as a replacement for the common 12V lead acid battery.

The new generation Li-ion battery adopt Iron Phosphate (LiFePO<sub>4</sub>) cells and unique BMS to provide safety, high current and prominent long life performance, with 20 times longer cyclic life than SLA battery to save cost and energy, up to 70% lighter than SLA battery to save logistic cost.

This document is intended for use by anyone required to install and operate new generation Li-ion batteries. Be sure to review this manual carefully to identify any potential safety risks before proceeding.

The owner must be familiar with all the features of this product before proceeding.

Failure to install or use this product as instructed can result in damage to the product that may not be covered under the limited warranty.

This manual suitable for below models:

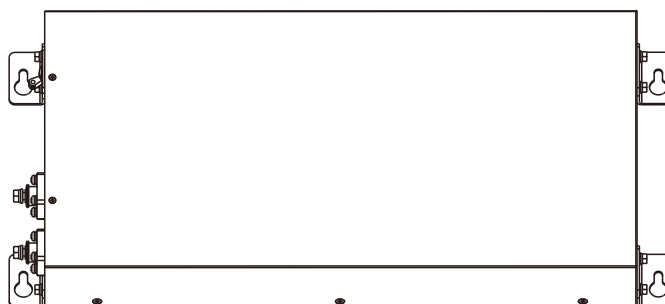

12.8V100Ah

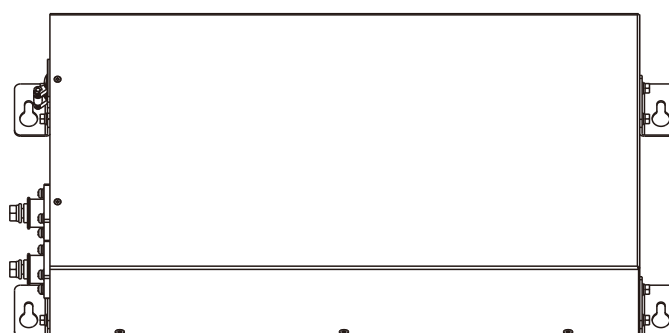

12.8V200Ah



## **WARNING:** Explosion, Electrocution, Or Fire Hazard

- A battery can present a risk of electric shock, burns from high short circuit current, fire, or explosion.
- Observe proper precautions.
- Ensure the cables are properly sized.
- Ensure clearance requirements are strictly enforced around the batteries according to local installation standards.
- Ensure the area around the batteries is well ventilated and clean of debris.
- Always use insulated tools. Avoid dropping tools onto batteries or other electrical parts.
- Never charge a frozen battery unless optional heater parts inside.
- If a battery must be removed. Make sure all devices are disconnected.
- Indoor/Undercover Use Only: Product is non-waterproof. Avoid direct sunlight, high humidity, or high-heat environments (e.g., under-bonnet).



## **IMPORTANT**

- Mandatory clearance/gap between batteries: >3mm.
  - When replacing batteries, use the same number and type of batteries.
  - Avoid any fall or collision during the installation process.
  - Do not remove the battery components. The maintenance of the battery should be carried out by a professional engineer.
  - Temperature Limits: Do not exceed 58°C during use or 60°C during storage.
  - Do not incinerate or expose to open flames.
  - Connection Limits: Max 8 batteries per bank (4S2P or 2S4P). Do not connect over 4 sets of 12.8V Li-ion batteries in series. Exceeding this limit will damage the BMS & void the warranty.
  - Series Connection: Fully charge each battery individually before connecting them. Uneven SOC will reduce the total usable capacity and may cause malfunctioning.
  - Communication function: If any batteries are connected (or partially connected) in series, communication is not supported. Do not use automatic coding components in these setups.
  - Before parallel connection, ensure the voltage difference less than 0.1V to avoid large current impact.
  - Recharge the battery immediately after a full discharge. Leaving a battery empty can lead to BMS failure and permanent battery damage.
  - Use certified LFP charger for charging.
-

## Storage

The 12.8V Li-ion battery can be stored in an environment with temperatures between -20°C and +55°C and between 0% and 90% relative humidity, non-condensing.

- For long storage periods at 25°C, charge the battery every half year.
- For temperatures above 40°C, charge the battery quarterly. The battery SOC is 50% during delivery, It needs to recharge after 9~10 months during storage.
- Do not store the Li-ion battery at temperatures above 60°C.
- Do not store a fully discharged battery for long time. This can cause the BMS to fail and result in permanent battery damage (scrap).

## Relationship Between Charge Limits and Temperature

Due to the chemistry of Lithium Ion cells, the cells cannot accept as much charge current at lower temperatures without risking permanent loss of capacity. As the cells' temperature rises during the charging process, they can gradually accept higher currents.

To maintain optimum performance and durability of Li-ion battery, the following charge limits based on ambient temperature is recommended.

Temperature (°C)	Max. Charge Current
-20	Prohibit charging
-10	Prohibit charging
0	0.1C
10	Recommended charge current
20	Max. continuous charge current
35	Recommended charge current
45	0.2C
>55	Prohibit charging

Table 1 Charge Rate by Temperature

# Installation

**Turn off breaker during installation.**

1. Install the mounting brackets onto the battery. Pay attention to the left and right orientation of the mounting brackets. Incorrect installation will cause the battery cells to face downwards when wall-mounted, increasing the risk of a short circuit in high-vibration environments.

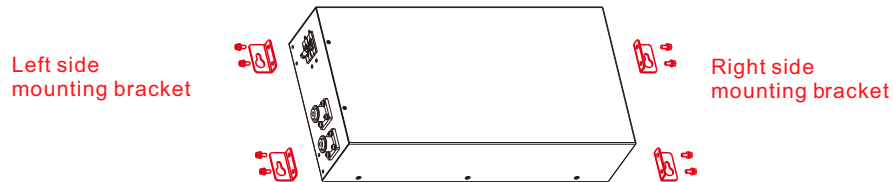

Description	Qty	Remark
Right side mounting brackets, SPCC -2.0mm 50.0*30.0*20.0mm, L-shaped, ROHS, 1.2.A.00537	2	
Left side mounting brackets, SPCC -2.0mm 50.0*30.0*20.0mm, L-shaped, ROHS, 1.2.A.00538	2	
Cross round head combination bolt M5*10 Stainless steel 304,ROHS	8	

## 2. Wall mounted installation

Drill holes on wall according to below dimension. Secure the wall mounting bracket to the wall using appropriate screws and washers. Tighten the screws in a clockwise direction.

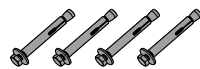

Expansion bolts M6\*60mm  
 stainless steel, ROHS  
 -4 Pcs

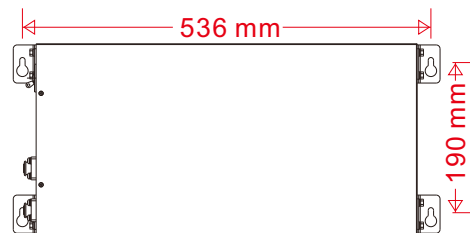

## 3. Power cable connection (recommended cable size & torque)

- 100A current- Power cable diameter 25mm<sup>2</sup>
- 150A current- Power cable diameter 35mm<sup>2</sup>
- 200A current- Power cable diameter 50mm<sup>2</sup>

- M6\* 16 bolts for 12.8V100Ah, Torque:8.8~12.5Nm
- M8\*16 bolts for 12.8V200Ah, Torque:19.6~27.9Nm

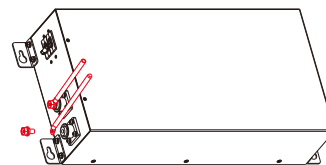

## 3. Turn ON breaker

Turn on breaker and battery output voltage will be 13.0~13.5Vdc

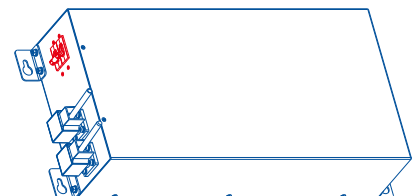

## Charging Batteries

### General Requirements:

**Charging Method:** A Constant Current / Constant Voltage (CC/CV) charging profile is required. Always use a charger specifically designed for LiFePO4 batteries. The battery includes a BMS. If the battery is over-discharged, the BMS may enter 'Under-Voltage Protection'. Ensure your charger has a "wake-up" or "0V" function to reset the BMS.

**Limits:** Charging and discharging currents must remain within the limits specified in the data sheet. Exceeding these limits will damage the battery and void the warranty.

**Warning:** Do not use chargers with "Auto-Rejuvenation" or "Auto-Pulse" modes. Never reverse-charge the battery.

### Charging Procedure (Single 12.8V Battery @ 25°C):

**Bulk Stage:** Charge at a constant current of 0.5C (50% of capacity) until the voltage reaches 13.8V – 14.6V. (Minimum 13.8V is required for a full charge. Refer to charging rates in 'Table 1').

**Absorption Stage:** Maintain a constant voltage (typically 13.8V) until the charging current drops below 0.02C. This ensures the cells reach 100% State of Charge (SOC).

**Termination:** Stop charging once the current decays to zero or the absorption stage is complete.

**Notes:** LiFePO4 batteries have a very low self-discharge rate. Float charging is not recommended, as it can reduce the battery's lifespan. Disconnect the charger once the battery is full.

**Important:** Do not use chargers capable of outputting higher voltages than 75V, even if choosing '14 x N' voltage setting to charge 'N' batteries in series ( $N \leq 4$ ). If the BMS cuts off, these chargers can create HV spikes that exceed BMS hardware limit and destroy it.

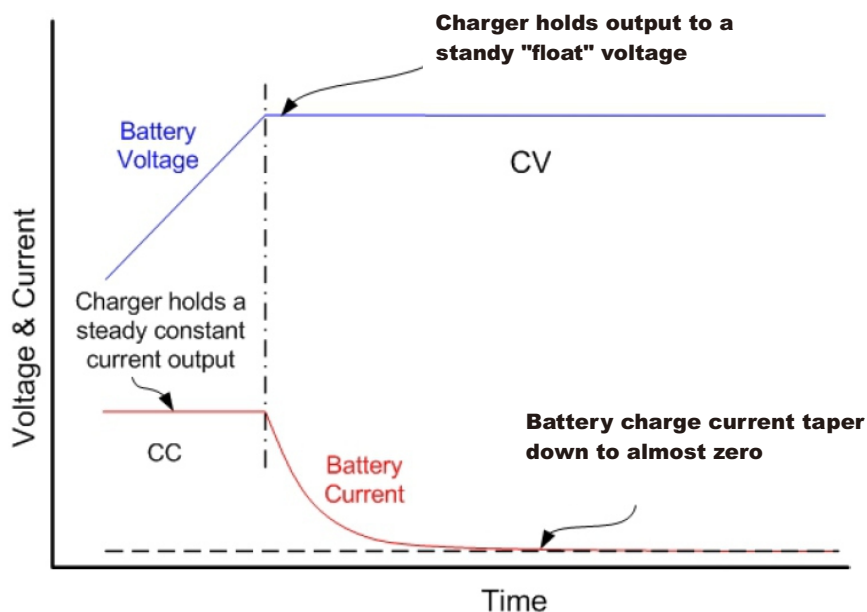

Battery Voltage and Current During Charge

## ON/OFF Button and LED Indicators

For A type Li-ion battery, if there are no charge or discharge for 24 hours, the battery will enter into sleep mode to save energy and it can still be measured a OCV (>10V), any charge or discharge operation will active the battery.

If the battery triggers its over-discharge protection, the BMS will enter Sleep Mode after 5 minutes. In this state, there is no OCV present. The battery can only be reactivated by initiating a charge operation.

It can also support to press ON/OFF button 6 seconds to active or switch off a battery.

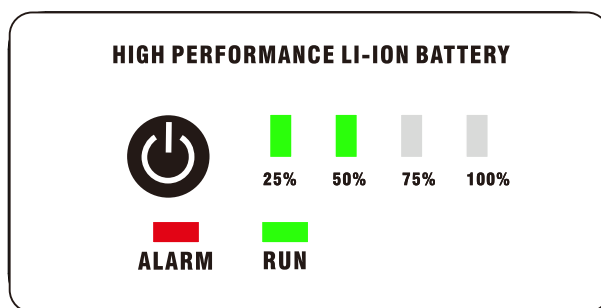

ON/OFF button and LED indicators

Status	Normal Warning Protection	RUN	ALM	SOC				Description
		●	●	●	●	●	●	
Shut down	Normal	OFF	OFF	OFF	OFF	OFF	OFF	
Standby	Normal	Flash 1	OFF	Follow module capacity				Standby
	Warning	Flash 1	Flash 2	Follow module capacity				Module at low voltage
Charge	Normal	ON	OFF	Follow module capacity				
	Warning	ON	Flash 2	Follow module capacity				
	Over-charge Protection	ON	OFF	ON	ON	ON	ON	LED turn to standby if no power supply
	Temperature / over-current / BMS fault protection	OFF	OFF	OFF	OFF	OFF	OFF	Stop charging
Discharge	Normal	ON	OFF	Follow module capacity				
	Warning	ON	Flash 2	Follow module capacity				
	Under voltage Protection	OFF	OFF	OFF	OFF	OFF	OFF	Stop discharging
	Temperature / over-current / short circuit / BMS fault protection	OFF	ON	OFF	OFF	OFF	OFF	Stop discharging
Failure		OFF	ON	OFF	OFF	OFF	OFF	Stop charging and discharging

Note:

Flash 1: light 0.25s/o ff3.75s; Flash 2: light 0.5s / o ff1.5s

## Communication Port

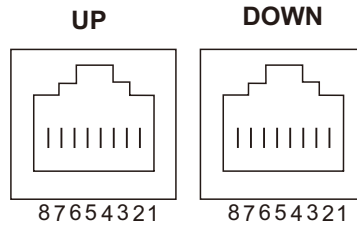

UP	
PIN	Description
1	LED -
2	O/F/LED+
3	O/F
4	CAN H
5	CAN L
6	COMG
7	RS485-A
8	RS485-B

DOWN	
PIN	Description
1	/
2	SWB
3	SWA
4	CAN H
5	CAN L
6	COMG
7	RS485-A
8	RS485-B

*Note :*

1. Inter-battery communication is supported when batteries are **only** connected in parallel.
2. Communication is **not supported** if any batteries are connected (fully or partially) in series.

## Communication connection

the battery BMS default ADD is 0, if the battery needs to do communication with inverter or there are 2 or more batteries connect in parallel. it needs set ADD. The below accessories is necessary for communication setting and connection.

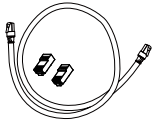

Communication cable-586B,CAT5e, 1m



CAN terminal resistor for parallel communication (Blue color, PIN4-PIN5 120 Ohm resistor)



Automatic coding parts for parallel batteries ADD automatic coding (Gray color, PIN2-PIN3 short together)

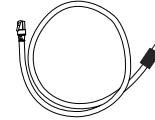

**Optional Part**  
RS485-USB device  
Only for install engineer and after-sale engineer.

Step 1. Connect the power cable between batteries. Make sure the screws are tight.

Step 2. Connect communication cable batteries and CAN terminal resistor.

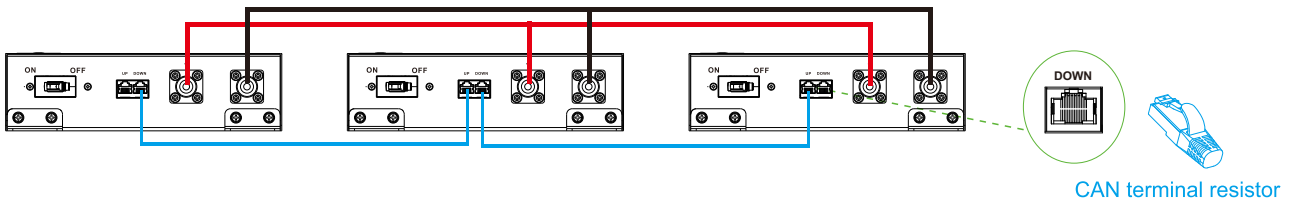

Step 3. Turn on breaker of all batteries, Press ON/OFF button 6s to active all batteries. the battery SOC indicator will on.

Step 4. Insert automatic coding parts to BAT-1 UP port. the BAT-1 RUN & ALARM LED will start to flash at the same time which means the BMS start setting ADD automatically. Finally, all LED indicators will become normal which means the BMS ADD coding process is complete.

Step 5: Remove automatic coding parts and connect RS485-USB cable to PC, it can monitor every battery information by BMS PC software. or connect BAT-1 UP port to inverter.

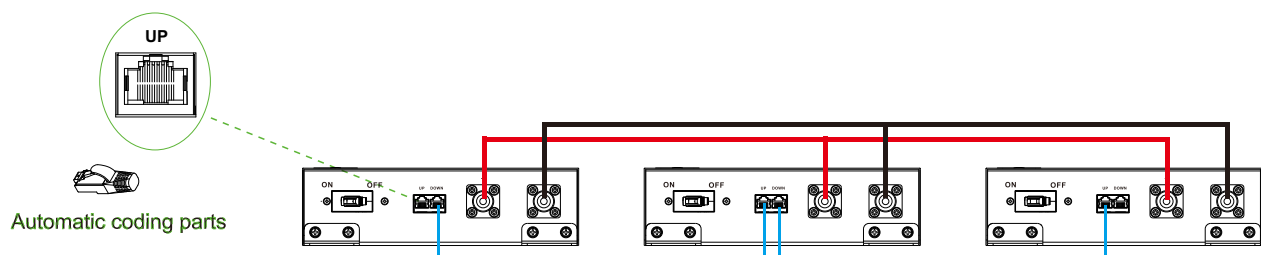

## Bluetooth battery APP introduction

The Bluetooth modules enable smart devices to monitor your battery(s). The "Neutron Power" app is designed to help you manage your lithium batteries more effectively by providing remote monitoring capabilities. By connecting your device to the app, you can access real-time information about the status of your batteries, including their charge levels, temperature, and other key metrics. This information can help you identify potential issues before they become major problems, allowing you to take proactive steps to ensure the health and longevity of your batteries.



Scan the QR code to open the App store or Play store

**Left Screenshot (Main Battery Status):**

- Battery Voltage:** 13.3 V
- Battery Current:** -4.4 A
- Charge control MOS & Discharge control MOS status:** C-MOS ON, D-MOS ON
- State of charge (SOC):** 38%
- Battery Rated Capacity:** 100.0 AH
- Battery Temperature:** 21 °C
- Cycle time:** 0

**Right Screenshot (Detailed Information):**

- Cell Voltage:** CELL-1: 3.342 V, CELL-2: 3.349 V, CELL-3: 3.339 V, CELL-4: 3.341 V
- Max Cell Voltage Difference:** 0.011 V
- Remain Capacity:** 38.0 AH
- System Status:** Charging
- Alarm & Protection:** Low temperature alarm, High temperature alarm, Over current alarm, Low voltage alarm, Low temperature protection, High temperature protection, Over current protection, Short current protection, Low voltage protection

*Note :*

1. Bluetooth module is optional parts for new generation Li-ion battery.

## Troubleshooting

The 12.8V Li-ion batteries are extremely reliable batteries that provide longer service life than comparable 12V lead-acid batteries. While highly durable, performance issues may occasionally arise typically due to misuse, improper storage, or non-optimal operating conditions. This section outlines potential issues and provides the appropriate troubleshooting procedures to resolve them.

### Charger Trips using Constant Voltage

**Problem:** CV charger trips when charging the batteries. This is due to the low impedance of the battery creating a current inrush that exceeds the charger's limits.

**Solution:** Reset the charger to clear the fault and restart the charging process.

### Terminal Voltage Absent or Low

**Problem:**

A multimeter reading indicates that the battery terminal voltage is low or non-existent.

Possible causes for this problem are:

The voltage of a cell dropped below 2V, triggering the BMS under-voltage protection.

The battery's SOC dropped below 5% due to an extended idle period or heavy use, causing the battery to enter under-voltage protection mode.

The battery overheated, leading the microprocessor to enable over-temperature protection.

**Solution:**

To resolve situations where terminal voltage is absent or low:

1. Allow the battery to cool to room temperature, and then re-check the terminal voltage.
  2. Connect the battery to a compatible charger to 'wake' the battery from protection mode. Once the voltage returns, allow the battery to remain on the charger. Depending on the depth of discharge and state of balance, it may take up to 48 hours to fully charge and balance the battery. Always recharge after use. Storing a depleted battery can cause the voltage to drop below the recoverable threshold, leading to permanent failure.
  3. Implement discharge controls to prevent over-discharge: Install a voltage cut-off device or an SOC (State of Charge) controller to automatically disconnect loads. Maintain a DOD of 80% or less (leaving a 20% reserve). This practice optimizes cell chemistry & significantly extends the battery's cycle life.
-

## Battery Current Disappears when Charging

### **Problem :**

Battery current disappears when charging. Possible causes for this problem are:

The battery overheated, enabling over-temperature protection.

The battery pack is out-of-balance.

Charger voltage is too high.

### **Solution:**

To resolve situations where current disappears when charging:

1.Allow the battery to cool.

2.Apply a 14.0 V charge voltage for 48 hours to balance the battery pack's cells.

3.Reduce charger voltage to 14.4 V or less.