

**BOSCH**

Invented for life

Bosch SMT Mega Power Plus

73011 – 12V Calcium-Calcium Technology

Applications

Light & Heavy Commercial Applications including Industrial

Bosch Master Data

Short Order Part Number	Bosch 13 Digit Part Number	EAN Barcode
73011	0092S37072C1U	4047026240320
Product Series	Technology	Warranty Period
SMT Mega Power Plus	Calcium, Calcium	Refer www.boschaftermarket.com.au
		Refer www.boschaftermarket.co.nz

Technical Information

Nominal Voltage	Nominal Capacity (20HR)	Reserve Capacity
12V	230 AH	430 Mins
Cold Cranking Amperes (CCA)		
1250 Amps		

Case Size Dimension

Length	Width	Container Height
518mm (20.4 inches)	273mm (10.75 inches)	214mm (8.42 inches)
Total Height (with Terminal)		
236mm (9.29 inches)		

Approx Weight (Gross)	Terminal	Grid Design
53 kg (116 lbs)	E (Standard)	Expanded
Container Material	Lid Design	Cold Cranking Amperes (CCA)
Polypropylene	SMF	1200 Amps
Lifecycle Heavy Load (Class B)	Rated Capacity	
175	Mins @ 25A = 430 (20hr, 1.75V/cell, 26.7°C/80°F) = 230 AH	
Operating Temp. Range	Nominal Operating Temp. Range	
Discharge: -30~75°C (-22~167°F)	25°C/77°F	

Product Dimension & Design

■ E (Standard)

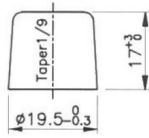

POSITIVE TERMINAL S=1:1

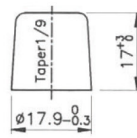

NEGATIVE TERMINAL S=1:1

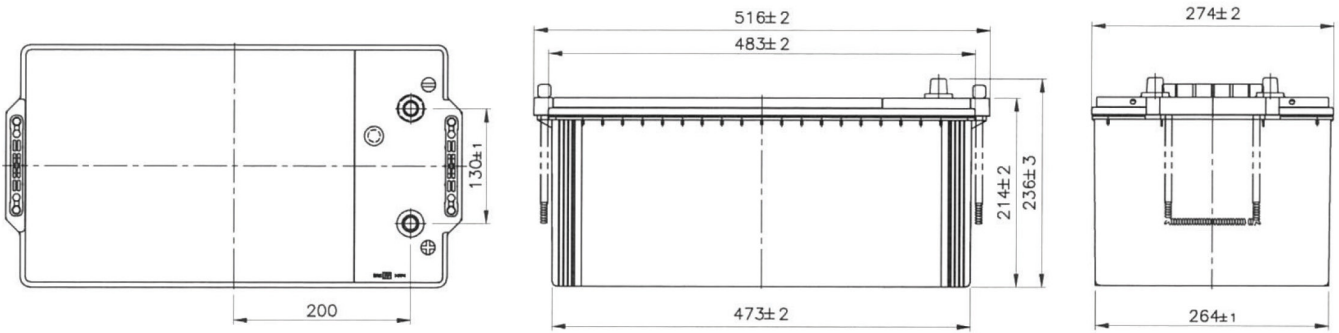

Your address for genuine Bosch quality:

Dealer stamp here: